

CHAPTER 12:

SPHERICAL COORDINATES

12.1 DEFINING OF SPHERICAL COORDINATES

A location in three dimensions can be defined with spherical coordinates (θ, ϕ, ρ) where

- θ is the same angle θ defined for polar and cylindrical coordinates. To gain some insight into this variable in three dimensions, the set of points consistent with some constant values of θ are shown below.

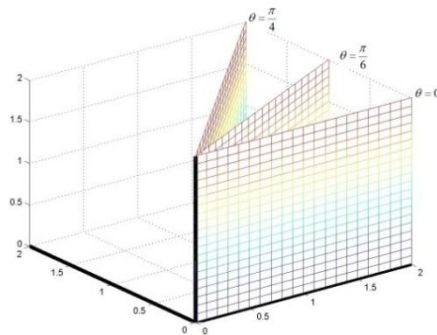

- ϕ is the angle between the vector that goes from the origin to the location and the vector $\langle 0,0,1 \rangle$ (the z axis). To gain some insight into this variable in three dimensions, the set of points consistent with some constant values of ϕ are shown below.

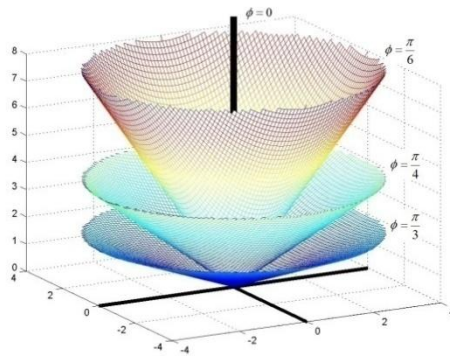

- ρ is the distance from the origin $(0, 0, 0)$ to the location.

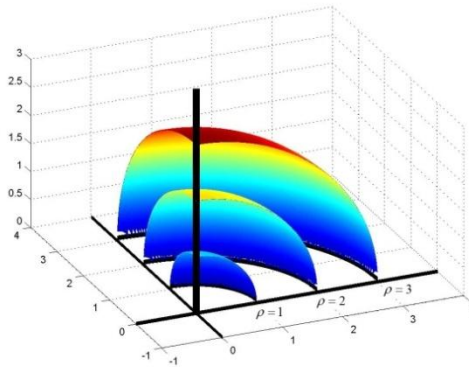

Example Exercise 12.1.1: Find the point $(\theta, \phi, \rho) = (150^\circ, 30^\circ, 5)$.

Solution: The first requirement of the location is that $\theta = 150^\circ$. The following diagram shows all points in the xy plane associated with $\theta = 150^\circ$.

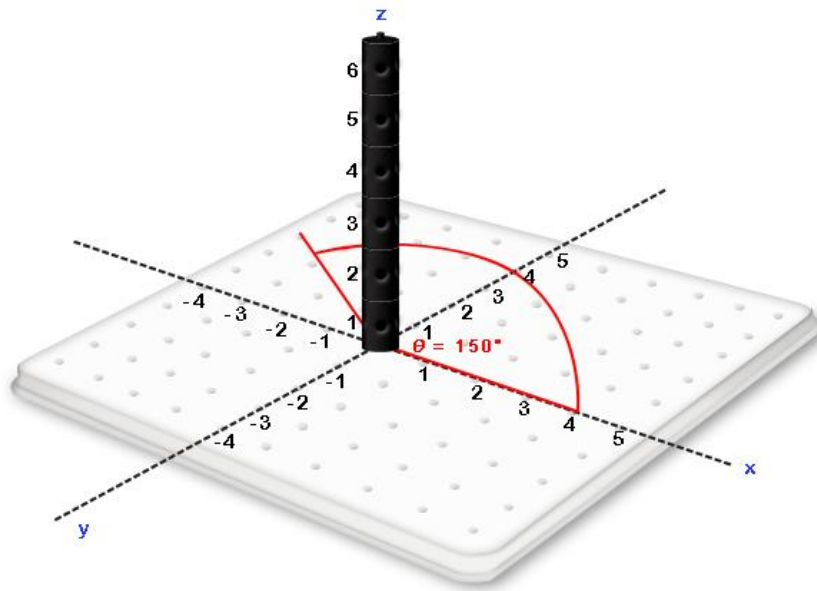

The second requirement of the location is that $\phi = 30^\circ$. The following diagram shows the set of points in the xy plane consistent with $\theta = 150^\circ$ (these can be visualized as a vector) rotated upward until the points on this vector achieve an angle of $\phi = 30^\circ$ with the z axis.

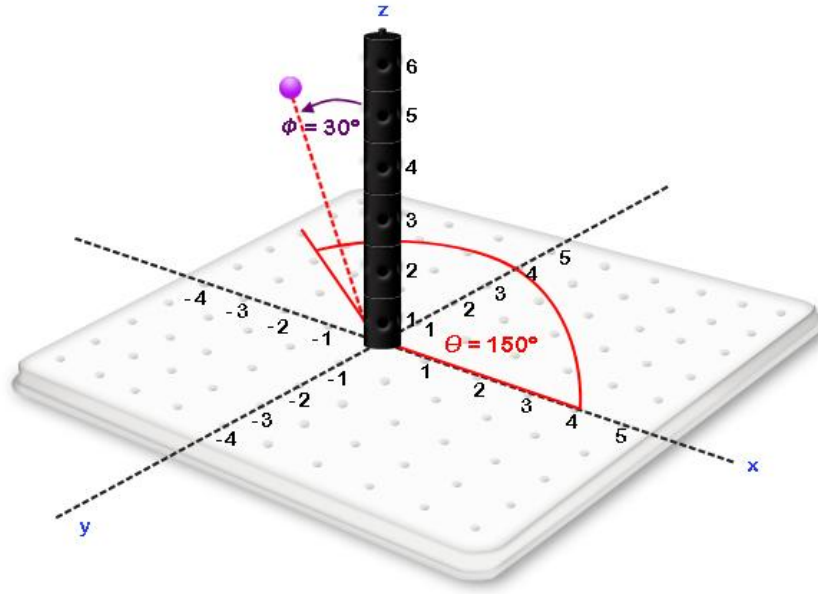

The set of points where $\theta = 150^\circ$ and $\phi = 30^\circ$ can be visualized as the vector shown in the above diagram. If we start at the origin and proceed along this vector until the distance from the origin is $\rho = 5$, we will obtain the location or point associated with $(\theta, \phi, \rho) = (150^\circ, 30^\circ, 5)$ in 3-space.

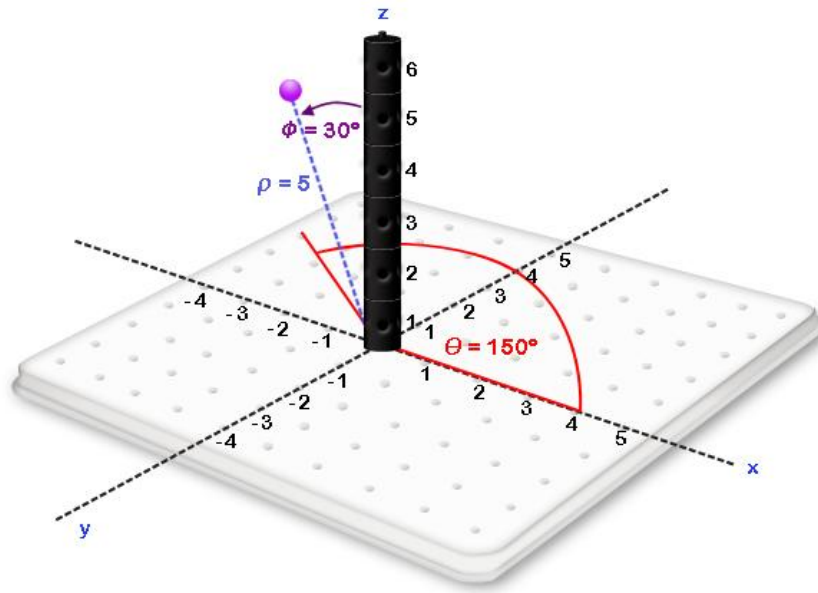

Example Exercise 12.1.2: Find the point $(\theta, \phi, \rho) = (30^\circ, 120^\circ, 6)$.

Solution: Starting with $\theta = 30^\circ$ we can obtain the points associated with $\theta = 30^\circ$ in the xy plane.

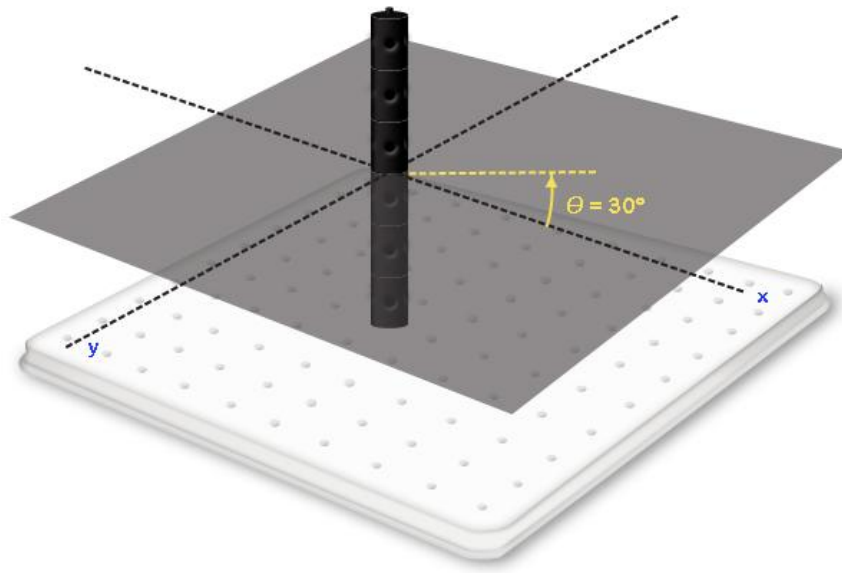

Finally, of those where $\theta = 30^\circ$ and $\phi = 30^\circ$, we can find the point with a distance of $\rho = 6$ from the origin. Hence the point associated with $(\theta, \phi, \rho) = (30^\circ, 120^\circ, 6)$ can be placed in 3-space.

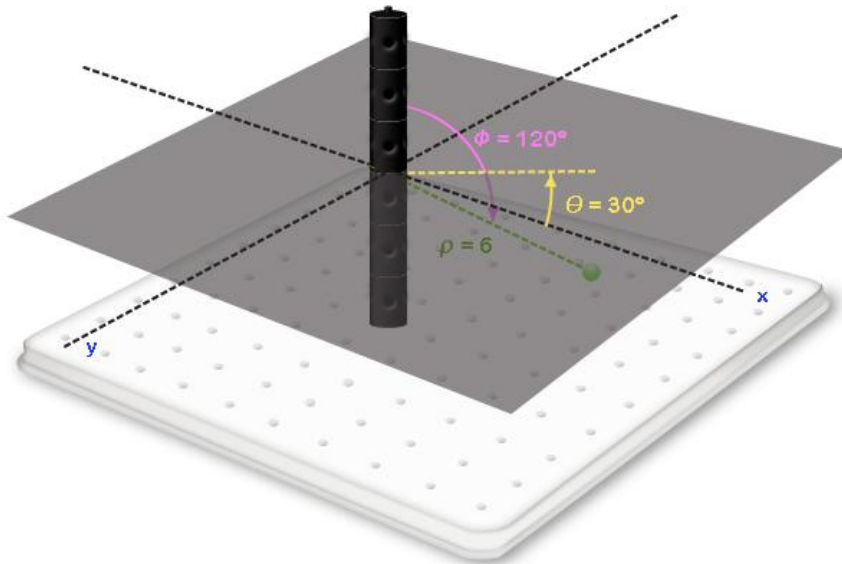

12.2 IDENTIFYING SOLIDS ASSOCIATED WITH SPHERICAL CUBES

We have previously seen that as cubic coordinates go from constant to constant, the resulting solid will be a cube. If cylindrical coordinates go from constant to constant, the resulting solid will be a cylinder or a segment of a cylinder. Hence, our expectation is that spherical

coordinates have been designed so that if each coordinate goes from constant to constant, the resulting solid will be a sphere or a segment of a sphere.

Example Exercise 12.2.1: Find the volume associated with $0 \leq \theta \leq \frac{\pi}{2}, \frac{\pi}{4} \leq \phi \leq \frac{\pi}{2}, 2 \leq \rho \leq 4$

Solution: The region in the xy plane associated with $0 \leq \theta \leq \frac{\pi}{2}$ is shown in the diagram below.

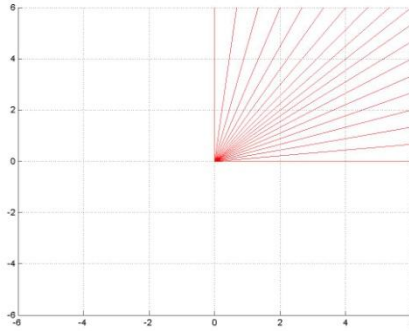

If each of the vectors shown in red in the above diagram is rotated upward from the origin to the z axis, this will reflect the points associated with $\phi = 0$ for each value of θ . If it is rotated back to the xy plane, this will reflect a value of $\phi = \frac{\pi}{2}$ for each value of θ . If it is rotated halfway between the z axis and the xy plane, this will reflect a value of $\phi = \frac{\pi}{4}$ for each value of θ . Hence the set of points consistent with $0 \leq \theta \leq \frac{\pi}{2}$ and $\frac{\pi}{4} \leq \phi \leq \frac{\pi}{2}$ will be the points above the first quadrant in the xy plane and below the cone $\phi = \frac{\pi}{4}$ shown in the diagram below.

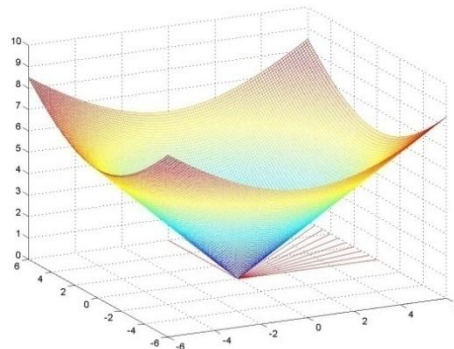

The volume associated with $0 \leq \theta \leq \frac{\pi}{2}, \frac{\pi}{4} \leq \phi \leq \frac{\pi}{2}, 2 \leq \rho \leq 4$ will be the points in the above solid that reside between the spheres $\rho = 2$ and $\rho = 4$. This spherical cube is shown in the diagram below.

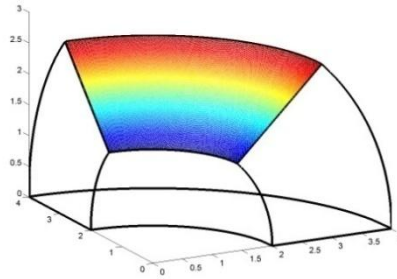

In the above case, when spherical coordinates went from constant to constant, the resulting solid was a segment of a sphere. If we repeat the above steps with $0 \leq \theta \leq 2\pi, 0 \leq \phi \leq \pi, 0 \leq \rho \leq R$, the resulting solid will be an entire sphere of radius R centered at $(0,0,0)$.

12.3 TRANSLATING COORDINATE SYSTEMS

We now have three different coordinate systems with which we can represent a point in 3-space. A point can be represented with (x, y, z) in cubic coordinates, with (r, θ, z) in cylindrical coordinates and with (θ, ϕ, ρ) in spherical coordinates. It is often helpful to translate a problem from one coordinate system to another depending on the nature of the problem. As a first step, the geometry of each of the coordinates in these three coordinate systems is presented in the following diagram.

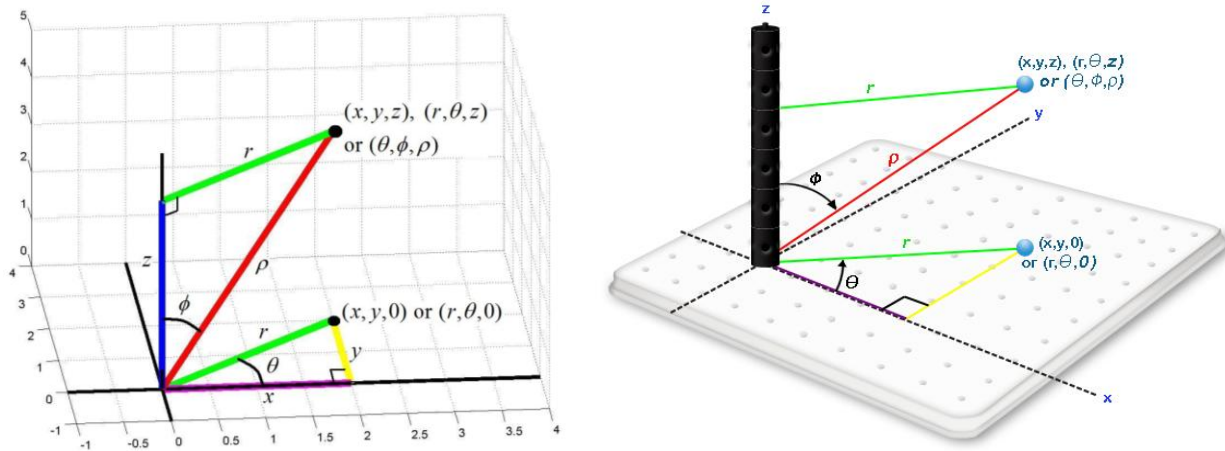

The right triangle in the xy plane with angle θ produces the following relationships between rectangular and polar coordinates that we should already be familiar with:

- $x = r\cos(\theta)$,
- $y = r\sin(\theta)$,
- $x^2 + y^2 = r^2$ or $r = \sqrt{x^2 + y^2}$ and

- $\tan(\theta) = \frac{y}{x}$ or $\theta = \tan^{-1}\left(\frac{y}{x}\right)$ when (x, y) is in the first or fourth quadrant and $\theta = \tan^{-1}\left(\frac{y}{x}\right) + \pi$ when the point (x, y) is in the second or third quadrant

The right triangle with angle ϕ produces the following relationships:

- $z = \rho \cos(\phi)$,
- $r = \rho \sin(\phi)$,
- $z^2 + r^2 = \rho^2$ or $\rho = \sqrt{z^2 + r^2}$ and
- $\tan(\phi) = \frac{r}{z}$ or $\phi = \tan^{-1}\left(\frac{r}{z}\right)$

Putting some of these relationships together we obtain:

- $x = r \cos(\theta)$ and $r = \rho \sin(\phi)$ so $x = \rho \sin(\phi) \cos(\theta)$
- $y = r \sin(\theta)$ and $r = \rho \sin(\phi)$ so $y = \rho \sin(\phi) \sin(\theta)$,
- $z^2 + r^2 = \rho^2$ and $x^2 + y^2 = r^2$ so $x^2 + y^2 + z^2 = \rho^2$ or $\rho = \sqrt{x^2 + y^2 + z^2}$
- $\tan(\phi) = \frac{r}{z}$ and $r = \sqrt{x^2 + y^2}$ so $\phi = \tan^{-1}\left(\frac{\sqrt{x^2 + y^2}}{z}\right)$

Organizing these conclusions, the following are the relations between spherical and cubic coordinates:

- $\rho = \sqrt{x^2 + y^2 + z^2}$
- $\phi = \tan^{-1}\left(\frac{\sqrt{x^2 + y^2}}{z}\right)$
- $\theta = \tan^{-1}\left(\frac{y}{x}\right)$ when (x, y) is in the first or fourth quadrant and $\theta = \tan^{-1}\left(\frac{y}{x}\right) + \pi$ when the point (x, y) is in the second or third quadrant
- $x = \rho \sin(\phi) \cos(\theta)$
- $y = \rho \sin(\phi) \sin(\theta)$
- $z = \rho \cos(\phi)$

The following are the relations between cylindrical and spherical coordinates:

- $z = \rho \cos(\phi)$,
- $r = \rho \sin(\phi)$
- $\theta = \theta$ as the coordinate is shared in both coordinate systems
- $\rho = \sqrt{z^2 + r^2}$ and
- $\phi = \tan^{-1}\left(\frac{r}{z}\right)$

12.4 APPROXIMATING THE VOLUME OF A SPHERICAL CUBE

To begin our discussion of the volume of a spherical cube, we will consider the solid $\frac{2\pi}{7} \leq \theta \leq \frac{3\pi}{7}, \frac{\pi}{5} \leq \phi \leq \frac{2\pi}{5}, 5 \leq \rho \leq 6$ shown in the diagram below.

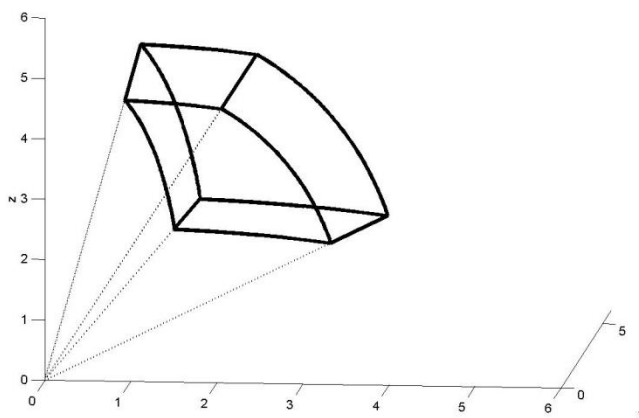

As with cylindrical cubes, we will approximate the volume of this cube with

$$\mathbf{Volume} = \mathit{length} \times \mathit{width} \times \mathit{height}$$

As $\Delta\theta \rightarrow 0, \Delta\phi \rightarrow 0$ and $\Delta\rho \rightarrow 0$, all corresponding sides will come to resemble parallel lines and this approximation will become precise.

Beginning with the width of the top and the bottom of the spherical cube, we can see in the diagram below that ρ goes from 5 to 6 on both the left and right sides of the top and the bottom. Correspondingly, we will approximate $\mathit{width} = \Delta\rho = 1$.

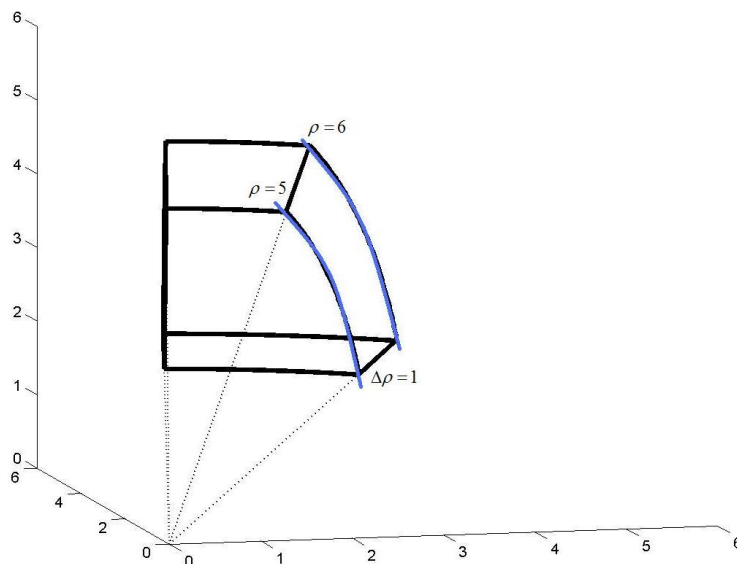

In the following diagram, we can see that the height of the cube on both the left and the right sides will be approximated with an arc that has angle $\Delta\phi = \frac{\pi}{5}$. The radius associated with the arc is equal to 5 on the inner side (side closer to the origin) of the cube and is equal to 6 on the outer side of the cube. Hence we will approximate $height = \rho\Delta\phi = 6 * \frac{\pi}{5}$ on the outer side of the cube and $height = \rho\Delta\phi = 5 * \frac{\pi}{5} = \pi$ on the inner side of the cube. As, $\Delta\phi \rightarrow 0$ and $\Delta\rho \rightarrow 0$, the arcs will approach linearity and the outer and inner heights will approach the same length.

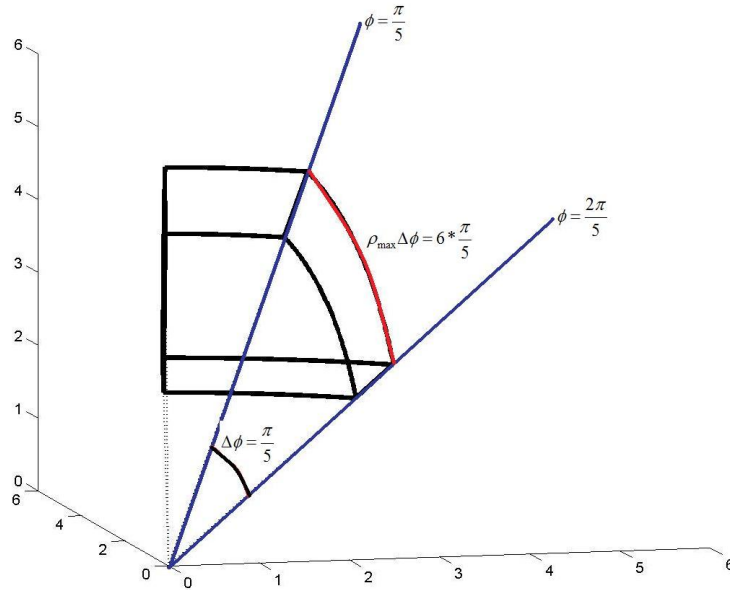

We now have approximated the height and the width of the cube however looking at the diagram, there are four different lengths: The bottom inner side, the bottom outer side, the top inner side and the top outer side. Starting with the inner sides, we can see in the diagram below that both the top and bottom lengths are arcs with angle $\Delta\theta = \frac{\pi}{7}$.

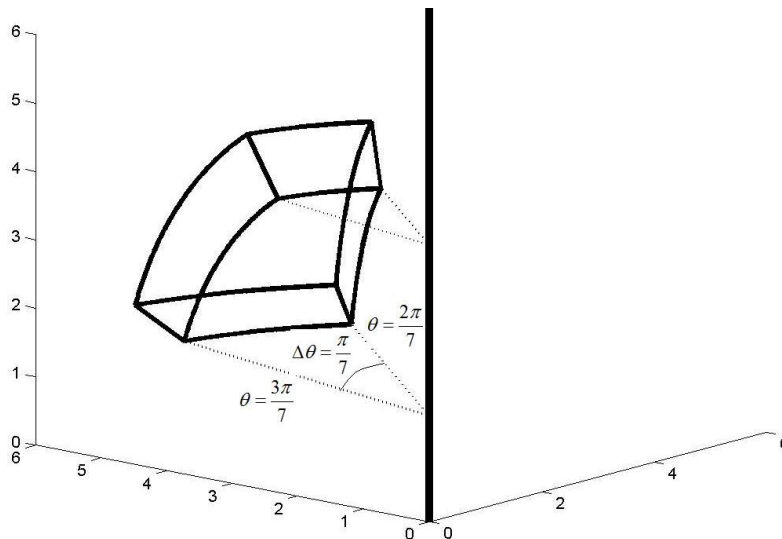

In the following diagram, we can see that the radius associated with the arc that represents the length of the top and the bottom side of the cube is the value r from cylindrical and polar coordinates. However we wish to represent the volume in spherical coordinates so we use the translation from section 12.3 that indicates $r = \rho \sin(\phi)$. The upper inner arc consists of points where $\rho = 5$ and $\phi = \frac{\pi}{5}$ and hence the radius of the upper inner arc is $\rho \sin(\phi) = 5 \sin\left(\frac{\pi}{5}\right)$.

The lower inner arc consists of points where $\rho = 5$ and $\phi = \frac{2\pi}{5}$ and hence the radius of the lower inner arc is $r = \rho \sin(\phi) = 5 \sin\left(\frac{2\pi}{5}\right)$.

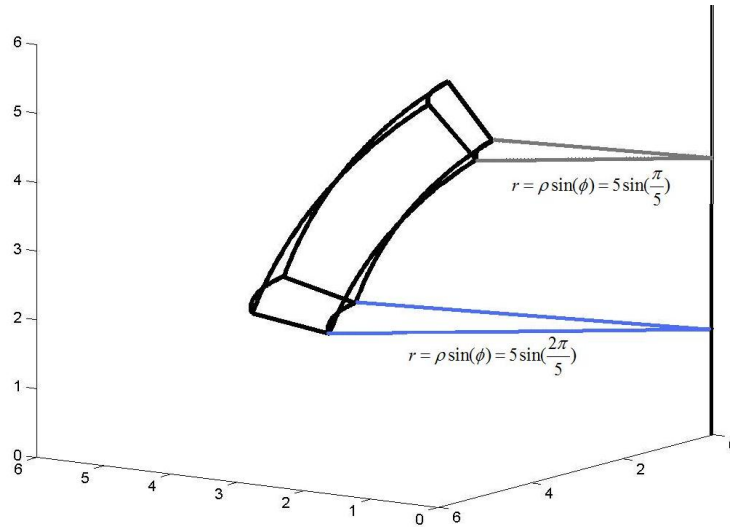

Hence the lower inner arc has angle $\Delta\theta = \frac{\pi}{7}$, radius $\rho \sin(\phi) = 5 \sin\left(\frac{2\pi}{5}\right)$ and our approximation for the length will be $length = \rho \sin(\phi) \Delta\theta = 5 \sin\left(\frac{2\pi}{5}\right) * \frac{\pi}{7}$. The upper inner arc has angle $\Delta\theta = \frac{\pi}{7}$, radius $\rho \sin(\phi) = 5 \sin\left(\frac{\pi}{5}\right)$ and our approximation for the length will be $length = \rho \sin(\phi) \Delta\theta = 5 \sin\left(\frac{\pi}{5}\right) * \frac{\pi}{7}$. The process to find the lengths of the outer arcs on the top and bottom sides of the cube is the same. The only difference is that the outer arcs use $\rho = 6$ and the inner arcs use $\rho = 5$.

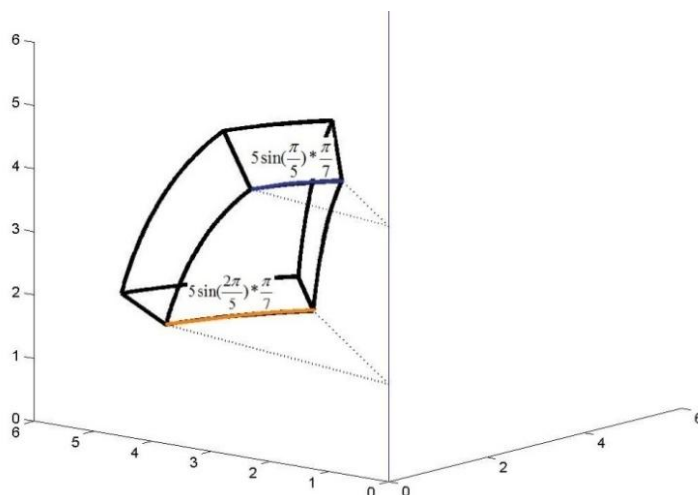

Generalization

When we approximate the volume of a spherical cube, we use

- $length = r\Delta\theta = \rho \sin(\phi) \Delta\theta$,
- $width = \Delta\rho$ and
- $height = \rho\Delta\phi$

to obtain,

$$Volume = \rho\Delta\phi * r\Delta\theta * \Delta\rho = \rho^2 \sin(\phi) \Delta\rho\Delta\phi\Delta\theta.$$

12.5 USING RIEMANN SUMS AND THE FUNDAMENTAL THEOREM TO OBTAIN THE MASS OF SPHERICAL CUBES

Example Exercise 12.5.1: A spherical cube $5 \leq \rho \leq 6$, $\frac{\pi}{4} \leq \theta \leq \frac{\pi}{2}$ and $\frac{\pi}{5} \leq \phi \leq \frac{2\pi}{5}$ has density $=(\theta) \frac{kg}{m^3}$. Use Riemann Sums with two divisions in ϕ , θ and ρ to approximate the mass of the cube using the largest value of each variable to represent a given division. Then express the Riemann Sum as a triple summation and use the fundamental theorem to find the precise mass of the cube.

Solution:

Step 1: Divide ϕ , θ and ρ into two parts and identify $\phi_1, \phi_2, \theta_1, \theta_2, \rho_1, \rho_2, \Delta\phi, \Delta\theta$ and $\Delta\rho$:

The following diagram shows the spherical cube associated with $5 \leq \rho \leq 6$, $\frac{\pi}{4} \leq \theta \leq \frac{\pi}{2}$ and $\frac{\pi}{5} \leq \phi \leq \frac{2\pi}{5}$.

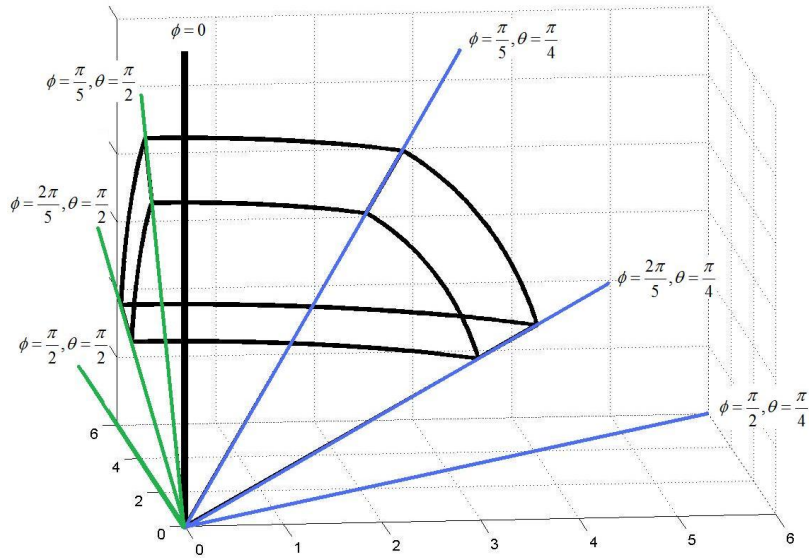

The following diagram shows the above spherical cube with two divisions in each variable.

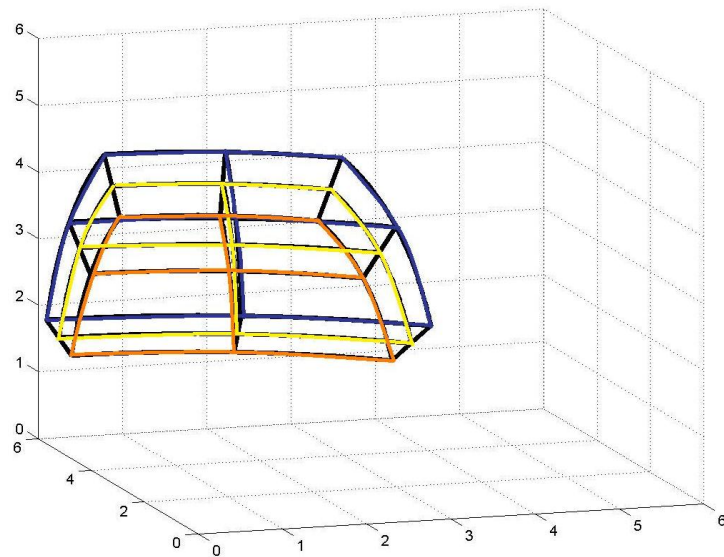

For convenience, we can divide the 8 divisions into the inner 4 divisions where $5 \leq \rho \leq 5.5$ and the outer four divisions where $5.5 \leq \rho \leq 6$ as is shown in the following diagrams

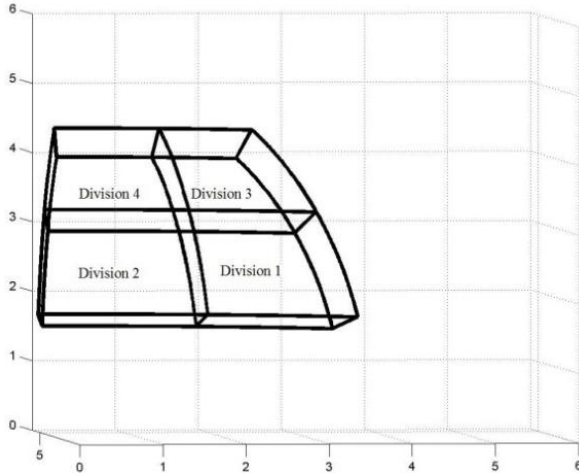

Inner Divisions: $5 \leq \rho \leq 5.5$

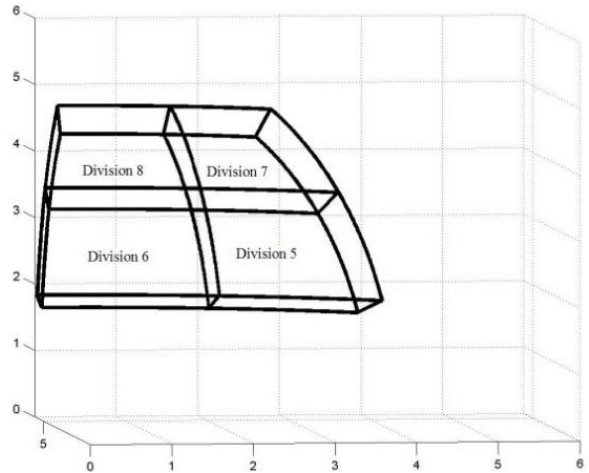

Outer Divisions: $5.5 \leq \rho \leq 6$

In divisions 1, 2, 5 and 6, ϕ goes from $\frac{\pi}{5}$ to $\frac{3\pi}{10}$ and in divisions 3, 4, 7 and 8, ϕ goes from $\frac{3\pi}{10}$ to $\frac{2\pi}{5}$.
 In divisions 1, 3, 5 and 7, θ goes from $\frac{\pi}{4}$ to $\frac{\pi}{2}$ and in divisions 2, 4, 6 and 8, θ goes from $\frac{\pi}{2}$ to $\frac{3\pi}{4}$.
 In divisions 1, 2, 3 and 4, ρ goes from 5 to 5.5 and in divisions 5, 6, 7 and 8, ρ goes from 5.5 to 6. Hence, $\phi_1 = \frac{3\pi}{10}$, $\phi_2 = \frac{2\pi}{5}$, $\theta_1 = \frac{3\pi}{8}$, $\theta_2 = \frac{\pi}{2}$, $\rho_1 = 5.5$, $\rho_2 = 6$, $\Delta\phi = \frac{\pi}{5}$, $\Delta\theta = \frac{\pi}{8}$ and $\Delta\rho = 0.5$

Step 2: Find the appropriate numeric approximation for the length, width, height, volume, density and mass for each division:

In Section 12.4, we approximated the volume of a polar cube with $volume = length * width * height$ where $length = r\Delta\theta = \rho \sin(\phi) \Delta\theta$, $width = \Delta\rho$ and $height = \rho\Delta\phi$. Using the maximum value of each variable in each division, the following two diagrams show the length, width, height and density for the 4 inner divisions and the four outer divisions.

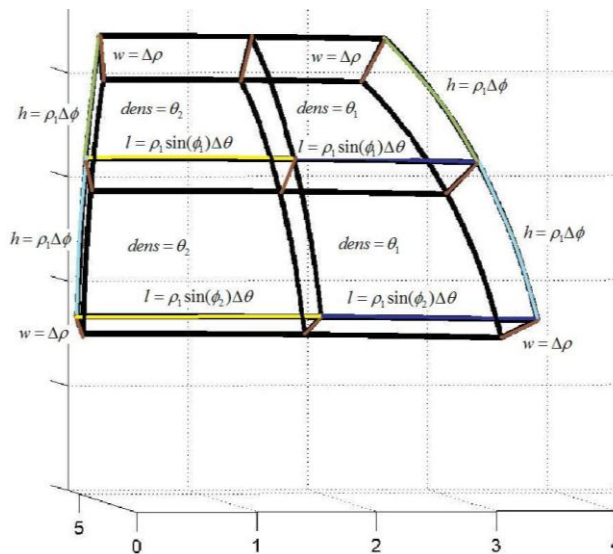

Inner Divisions: $5 \leq \rho \leq 5.5$

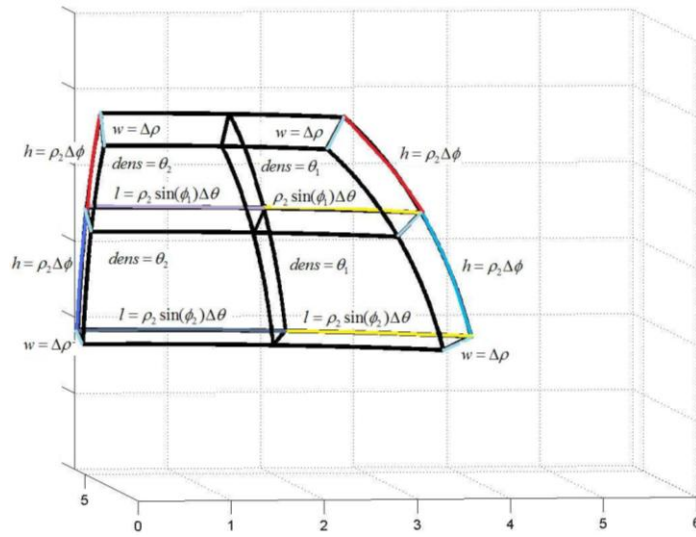

Outer Divisions: $5.5 \leq \rho \leq 6$

The length, width, height, density and mass of each division are summarized in the following table:

Division	Length (m)	Width (m)	Height (m)	Density ($\frac{kg}{m^3}$)	Mass (kg)
1	$5.5 * \sin\left(\frac{2\pi}{5}\right) * \frac{\pi}{4}$	0.5	$5.5 * \frac{\pi}{5}$	$\frac{3\pi}{8}$	$5.5^2 * \frac{3\pi}{8} * \sin\left(\frac{2\pi}{5}\right) * \frac{\pi^2}{40}$
2	$5.5 * \sin\left(\frac{2\pi}{5}\right) * \frac{\pi}{4}$	0.5	$5.5 * \frac{\pi}{5}$	$\frac{\pi}{2}$	$5.5^2 * \frac{\pi}{2} * \sin\left(\frac{\pi}{5}\right) * \frac{\pi^2}{40}$
3	$5.5 * \sin\left(\frac{\pi}{5}\right) * \frac{\pi}{4}$	0.5	$5.5 * \frac{\pi}{5}$	$\frac{3\pi}{8}$	$5.5^2 * \frac{3\pi}{8} * \sin\left(\frac{2\pi}{5}\right) * \frac{\pi^2}{40}$
4	$5.5 * \sin\left(\frac{\pi}{5}\right) * \frac{\pi}{4}$	0.5	$5.5 * \frac{\pi}{5}$	$\frac{\pi}{2}$	$5.5^2 * \frac{\pi}{2} * \sin\left(\frac{\pi}{5}\right) * \frac{\pi^2}{40}$
5	$6 * \sin\left(\frac{2\pi}{5}\right) * \frac{\pi}{4}$	0.5	$6 * \frac{\pi}{5}$	$\frac{3\pi}{8}$	$36 * \frac{3\pi}{8} * \sin\left(\frac{2\pi}{5}\right) * \frac{\pi^2}{40}$
6	$6 * \sin\left(\frac{2\pi}{5}\right) * \frac{\pi}{4}$	0.5	$6 * \frac{\pi}{5}$	$\frac{\pi}{2}$	$36 * \frac{\pi}{2} * \sin\left(\frac{2\pi}{5}\right) * \frac{\pi^2}{40}$
7	$6 * \sin\left(\frac{\pi}{5}\right) * \frac{\pi}{4}$	0.5	$6 * \frac{\pi}{5}$	$\frac{3\pi}{8}$	$36 * \frac{3\pi}{8} * \sin\left(\frac{\pi}{5}\right) * \frac{\pi^2}{40}$
8	$6 * \sin\left(\frac{\pi}{5}\right) * \frac{\pi}{4}$	0.5	$6 * \frac{\pi}{5}$	$\frac{\pi}{2}$	$36 * \frac{\pi}{2} * \sin\left(\frac{\pi}{5}\right) * \frac{\pi^2}{40}$

Step 3: Add the masses of the eight divisions to approximate the total mass of the solid:

$$\begin{aligned} \text{Mass} \approx & 5.5^2 * \frac{3\pi}{8} * \sin\left(\frac{2\pi}{5}\right) * \frac{\pi^2}{40} + 5.5^2 * \frac{\pi}{2} * \sin\left(\frac{\pi}{5}\right) * \frac{\pi^2}{40} + 5.5^2 * \frac{3\pi}{8} * \sin\left(\frac{2\pi}{5}\right) * \frac{\pi^2}{40} + \\ & 5.5^2 * \frac{\pi}{2} * \sin\left(\frac{\pi}{5}\right) * \frac{\pi^2}{40} + 36 * \frac{3\pi}{8} * \sin\left(\frac{2\pi}{5}\right) * \frac{\pi^2}{40} + 36 * \frac{\pi}{2} * \sin\left(\frac{2\pi}{5}\right) * \frac{\pi^2}{40} + 36 * \frac{3\pi}{8} * \sin\left(\frac{\pi}{5}\right) * \\ & \frac{\pi^2}{40} + 36 * \frac{\pi}{2} * \sin\left(\frac{\pi}{5}\right) * \frac{\pi^2}{40} \end{aligned}$$

Step 4: Repeat Step 2 using $\phi_1, \phi_2, \theta_1, \theta_2, \rho_1, \rho_2, \Delta\phi, \Delta\theta$ and $\Delta\rho$ instead of numerical values as appropriate.

Division	Length (m)	Width (m)	Height (m)	Density ($\frac{kg}{m^3}$)	Mass (kg)
1	$\rho_1 \sin(\phi_2) \Delta\theta$	$\Delta\rho$	$\rho_1 \Delta\phi$	θ_1	$\theta_1 \rho_1^2 \sin(\phi_2) \Delta\rho \Delta\phi \Delta\theta$
2	$\rho_1 \sin(\phi_2) \Delta\theta$	$\Delta\rho$	$\rho_1 \Delta\phi$	θ_2	$\theta_2 \rho_1^2 \sin(\phi_2) \Delta\rho \Delta\phi \Delta\theta$
3	$\rho_1 \sin(\phi_1) \Delta\theta$	$\Delta\rho$	$\rho_1 \Delta\phi$	θ_1	$\theta_1 \rho_1^2 \sin(\phi_1) \Delta\rho \Delta\phi \Delta\theta$
4	$\rho_1 \sin(\phi_1) \Delta\theta$	$\Delta\rho$	$\rho_1 \Delta\phi$	θ_2	$\theta_2 \rho_1^2 \sin(\phi_1) \Delta\rho \Delta\phi \Delta\theta$
5	$\rho_2 \sin(\phi_2) \Delta\theta$	$\Delta\rho$	$\rho_2 \Delta\phi$	θ_1	$\theta_1 \rho_2^2 \sin(\phi_2) \Delta\rho \Delta\phi \Delta\theta$
6	$\rho_2 \sin(\phi_2) \Delta\theta$	$\Delta\rho$	$\rho_2 \Delta\phi$	θ_2	$\theta_2 \rho_2^2 \sin(\phi_2) \Delta\rho \Delta\phi \Delta\theta$
7	$\rho_2 \sin(\phi_1) \Delta\theta$	$\Delta\rho$	$\rho_2 \Delta\phi$	θ_1	$\theta_1 \rho_2^2 \sin(\phi_1) \Delta\rho \Delta\phi \Delta\theta$
8	$\rho_2 \sin(\phi_1) \Delta\theta$	$\Delta\rho$	$\rho_2 \Delta\phi$	θ_2	$\theta_2 \rho_2^2 \sin(\phi_1) \Delta\rho \Delta\phi \Delta\theta$

Step 5: Add the masses of the eight divisions to approximate the total mass of the solid using $r_1, r_2, \theta_1, \theta_2, z_1, z_2, \Delta r, \Delta\theta$ and Δz :

$$\begin{aligned} \text{Mass} \approx & [\theta_1 \rho_1^2 \sin(\phi_2) \Delta\rho \Delta\phi \Delta\theta + \theta_2 \rho_1^2 \sin(\phi_2) \Delta\rho \Delta\phi \Delta\theta] + \\ & [\theta_1 \rho_1^2 \sin(\phi_1) \Delta\rho \Delta\phi \Delta\theta + \theta_2 \rho_1^2 \sin(\phi_1) \Delta\rho \Delta\phi \Delta\theta] + \\ & [\theta_1 \rho_2^2 \sin(\phi_2) \Delta\rho \Delta\phi \Delta\theta + \theta_2 \rho_2^2 \sin(\phi_2) \Delta\rho \Delta\phi \Delta\theta + \\ & [\theta_1 \rho_2^2 \sin(\phi_1) \Delta\rho \Delta\phi \Delta\theta + \theta_2 \rho_2^2 \sin(\phi_1) \Delta\rho \Delta\phi \Delta\theta] \end{aligned}$$

Step 6: Express the approximate mass in Step 5 as a triple summation:

$$\begin{aligned} \text{Mass} \approx & [\theta_1 \rho_1^2 \sin(\phi_2) \Delta\rho \Delta\phi \Delta\theta + \theta_2 \rho_1^2 \sin(\phi_2) \Delta\rho \Delta\phi \Delta\theta] + \\ & [\theta_1 \rho_1^2 \sin(\phi_1) \Delta\rho \Delta\phi \Delta\theta + \theta_2 \rho_1^2 \sin(\phi_1) \Delta\rho \Delta\phi \Delta\theta] + \\ & [\theta_1 \rho_2^2 \sin(\phi_2) \Delta\rho \Delta\phi \Delta\theta + \theta_2 \rho_2^2 \sin(\phi_2) \Delta\rho \Delta\phi \Delta\theta + \\ & [\theta_1 \rho_2^2 \sin(\phi_1) \Delta\rho \Delta\phi \Delta\theta + \theta_2 \rho_2^2 \sin(\phi_1) \Delta\rho \Delta\phi \Delta\theta] \end{aligned}$$

By grouping the [...], we obtain:

$$\begin{aligned} \text{Mass} \approx & \{ \sum_{k=1}^2 \theta_k \rho_1^2 \sin(\phi_2) \Delta\rho \Delta\phi \Delta\theta + \sum_{k=1}^2 \theta_k \rho_1^2 \sin(\phi_1) \Delta\rho \Delta\phi \Delta\theta \} + \\ & \{ \sum_{k=1}^2 \theta_k \rho_2^2 \sin(\phi_2) \Delta\rho \Delta\phi \Delta\theta + \sum_{k=1}^2 \theta_k \rho_2^2 \sin(\phi_1) \Delta\rho \Delta\phi \Delta\theta \}. \end{aligned}$$

By grouping the {...} (Note: The order within each bracket is ϕ_2 followed by ϕ_1 , however this makes no difference with a sum.), we obtain:

$$\mathbf{Mass} \approx \sum_{j=1}^2 \sum_{k=1}^2 \theta_k \rho_1^2 \sin(\phi_j) \Delta\rho \Delta\phi \Delta\theta + \sum_{j=1}^2 \sum_{k=1}^2 \theta_k \rho_2^2 \sin(\phi_j) \Delta\rho \Delta\phi \Delta\theta$$

Grouping these last two terms we obtain:

$$\mathbf{Mass} \approx \sum_{i=1}^2 \sum_{j=1}^2 \sum_{k=1}^2 \theta_k \rho_i^2 \sin(\phi_j) \Delta\rho \Delta\phi \Delta\theta$$

Step 7: As $\Delta\rho \rightarrow 0$, $\Delta\theta \rightarrow 0$ and $\Delta\phi \rightarrow 0$, this approximation becomes precise and we can apply the fundamental theorem to find the precise mass of the solid. Note that we change the order of expressions that are multiplied together so that the sigmas are coupled with the appropriate Δ 's.

$$\mathbf{Mass} = \lim_{\Delta\rho \rightarrow 0} \lim_{\Delta\phi \rightarrow 0} \lim_{\Delta\theta \rightarrow 0} \sum_{i=1}^2 \sum_{j=1}^2 \sum_{k=1}^2 \theta_k \rho_i^2 \sin(\phi_j) \Delta\theta \Delta\phi \Delta\rho$$

$$\mathbf{Mass} = \int_5^6 \int_{\frac{\pi}{5}}^{\frac{2\pi}{5}} \int_{\frac{\pi}{4}}^{\frac{\pi}{2}} \theta \rho^2 \sin(\phi) d\theta d\phi d\rho$$

12.6 VOLUMES ASSOCIATED WITH INTEGRALS IN SPHERICAL COORDINATES

Example Exercise 12.6.1: Find the solid associated with $\int_0^\pi \int_0^{\frac{\pi}{4}} \int_0^4 \rho^2 \sin(\phi) d\rho d\phi d\theta$

Solution: From the above section where we use the fundamental theorem and Riemann sums to find the volume of a spherical solid, we should remember that $\rho^2 \sin(\phi)$ is necessary for the expression of a volume in spherical coordinates. Hence the integral $\int_0^\pi \int_0^{\frac{\pi}{4}} \int_0^4 \rho^2 \sin(\phi) d\rho d\phi d\theta$ is simply a volume and were there a density f , it would be expressed as $\int_0^\pi \int_0^{\frac{\pi}{4}} \int_0^4 (f) \rho^2 \sin(\phi) d\rho d\phi d\theta$.

Working from the outside inward, the first datum from the integrals is $\int_0^\pi d\theta$ indicating that our volume will contain values of θ between $\theta = 0$ and $\theta = \pi$

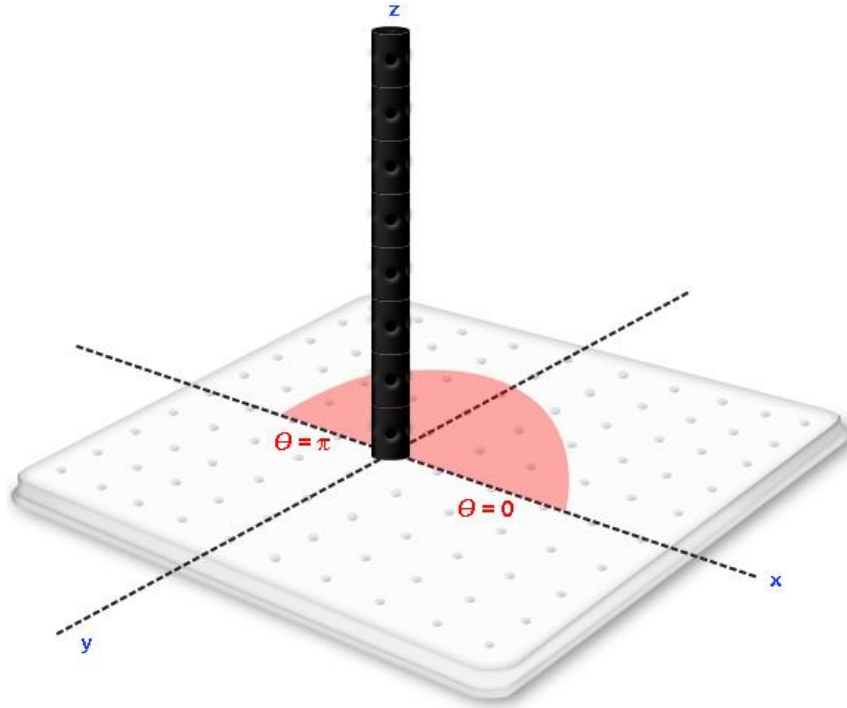

The second datum from the integral is $\int_0^{\pi/4} d\phi$ indicating that for every value of θ between $\theta = 0$ and $\theta = \pi$, we will accept values of ϕ that reside between $\phi = 0$ and $\phi = \frac{\pi}{4}$.

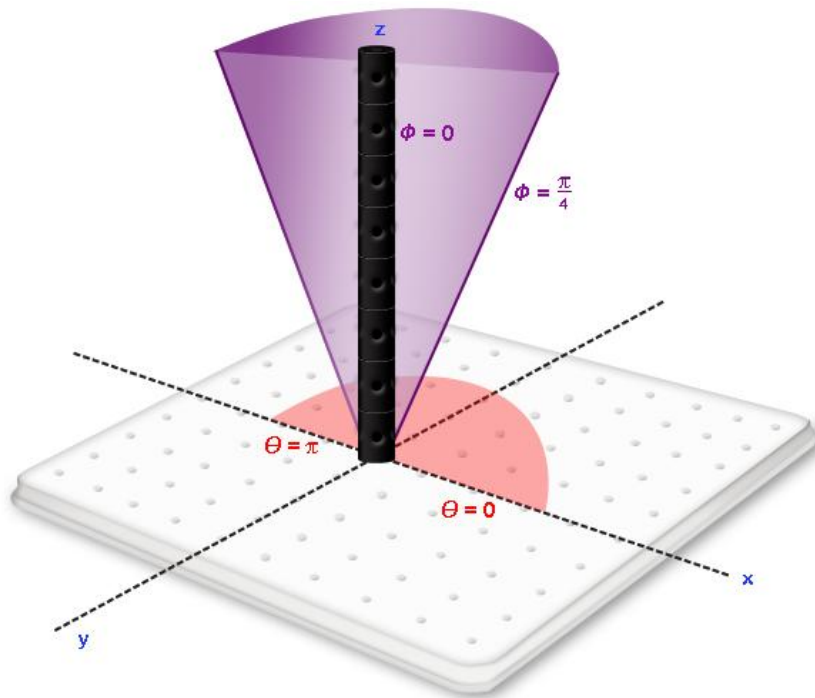

The third datum from the integral is $\int_0^4 d\rho$ indicating that for every value of θ and ϕ in the defined region, we will accept values of ρ that reside between $\rho = 0$ and $\rho = 4$. Taking all of the

data into account, this triple integral will represent the half of an ice cream cone shaped solid shown in the following diagram.

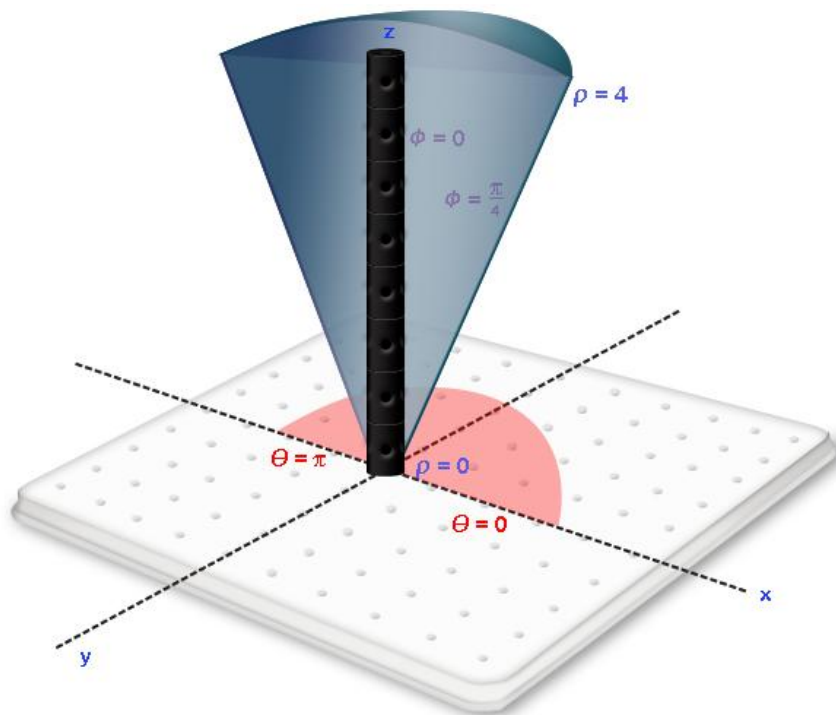

EXERCISE PROBLEMS:

1) Express the volume of the following solids as a triple integral in **(i)** spherical coordinates, **(ii)** cylindrical coordinates and **(iii)** cubic coordinates.

- A. Above the xy plane and below the sphere $x^2 + y^2 + z^2 = 9$.
- B. Below the xy plane and above the sphere $x^2 + y^2 + z^2 = 36$.
- C. Inside the sphere $x^2 + y^2 + z^2 = 49$ and satisfying that $x \leq 0$.
- D. Inside the sphere $x^2 + y^2 + z^2 = 25$ and satisfying that $x \leq 0$ and $y \leq 0$.
- E. Inside the sphere $x^2 + y^2 + z^2 = 64$ and satisfying that $z \leq 0$ and $y \leq 0$.
- F. Inside the sphere $x^2 + y^2 + z^2 = 4$, above the xy plane and satisfying that $x \leq 0$ and $y \geq 0$.
- G. Inside the sphere $x^2 + y^2 + z^2 = 1$, above the xy plane and satisfying that $x \leq y$ and $x \geq 0$.

2) The density of birds in a spherical cage is $\theta + \phi \frac{\text{birds}}{m^3}$ and we wish to obtain the number of fish in the tank described by $2 \leq \rho \leq 8, \frac{\pi}{2} \leq \theta \leq \frac{3\pi}{2}, \frac{\pi}{9} \leq \phi \leq \frac{\pi}{3}$.

- A. If there are two divisions in each variable and the number of fish is to be approximated using the minimum value for each variable in each division, find $\rho_1, \rho_2, \theta_1, \theta_2, \phi_1$ and ϕ_2 use them to fill in the following table with numerical values.

Division	Length	Width	Height	Density	No. of birds
1					
2					
3					
4					
5					
6					
7					
8					

- B. Use the values of $\rho_1, \rho_2, \theta_1, \theta_2, \phi_1$ and ϕ_2 to fill in the same table below using $\rho_1, \rho_2, \theta_1, \theta_2, \phi_1$ and ϕ_2 , and, $\Delta\rho, \Delta\theta$ and $\Delta\phi$ instead of numerical values. (Note, the divisions should not change between the two tables.)

Division	Length	Width	Height	Density	No. of birds
1					
2					
3					
4					
5					
6					
7					
8					

- C. Express the approximate no. of birds numerically.

- D. Express the number of birds obtained in part C in the form $\sum \sum \sum (...)\Delta\rho\Delta\phi\Delta\theta$ Take the appropriate limits to convert the sum in part D to an integral and evaluate the integral.

- 3) The density of fish in a spherical tank is $y \frac{\text{fishes}}{m^3}$ and we wish to obtain the number of fish in the tank described by $2 \leq \rho \leq 4, 0 \leq \theta \leq \frac{\pi}{2}, \frac{\pi}{4} \leq \phi \leq \frac{\pi}{2}$.

- A. If there are two divisions in each variable and the number of fish is to be approximated using the maximum value for each variable in each division, find $\rho_1, \rho_2, \theta_1, \theta_2, \phi_1$ and ϕ_2 use them to fill in the following table with numerical values.

Division	Length	Width	Height	Density	No. of fish
1					
2					
3					
4					
5					
6					
7					
8					

B. Use the values of $\rho_1, \rho_2, \theta_1, \theta_2, \phi_1$ and ϕ_2 to fill in the same table below using $\rho_1, \rho_2, \theta_1, \theta_2, \phi_1$ and ϕ_2 , and, $\Delta\rho, \Delta\theta$ and $\Delta\phi$ instead of numerical values. (Note, the divisions should not change between the two tables.)

Division	Length	Width	Height	Density	No. of fish
1					
2					
3					
4					
5					
6					
7					
8					

C. Express the approximate no. of fish numerically.

D. Express the number of fish obtained in part C in the form $\sum \sum \sum (\dots) \Delta\rho \Delta\phi \Delta\theta$ Take the appropriate limits to convert the sum.